



**G100**

**RIGGING**





# G100 RIGGING



KLR-704 G100 EYE SELFLOCK HOOK G100

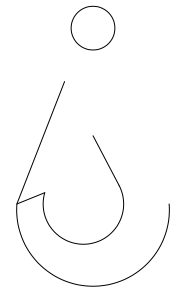

KLR-705 G100 CLEVIS SELFLOCK HOOK G100



Never exceed Working Load Limit

# G100 RIGGING



KLR-706 G100 SWIVEL SELFLOCK HOOK G100

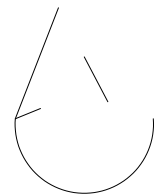

KLR-715 G100 CLEVIS FOREST HOOK G100



Never exceed Working Load Limit



**Never exceed Working Load Limit**

# G100 RIGGING



# G100 RIGGING



KLR-716 G100 CLEVIS LINK G100





KLR-714 G100 CLAW WITH SHEEP HORN EYE G100

Never exceed Working Load Limit

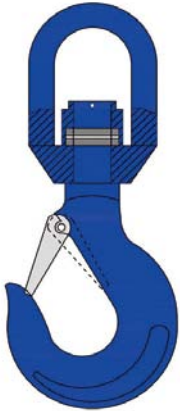
# G100 RIGGING

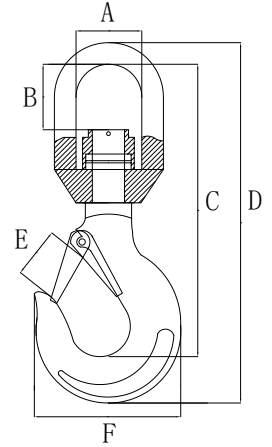

Fatigue tested at 1.5 times Working Load Limit for 20000



KLR-782 G100 SWIVEL HOOK WITH BEARING G100

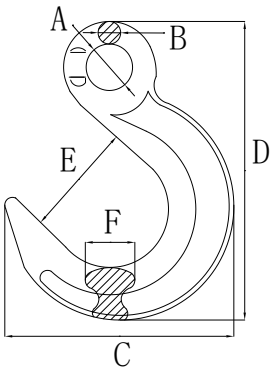

Fatigue tested at 1.5 times Working Load Limit for 20000

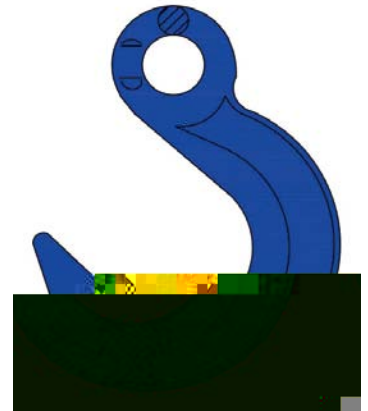

KLR-786 G100 EYE FOUNDRY HOOK G100



Never exceed Working Load Limit



# G100 RIGGING

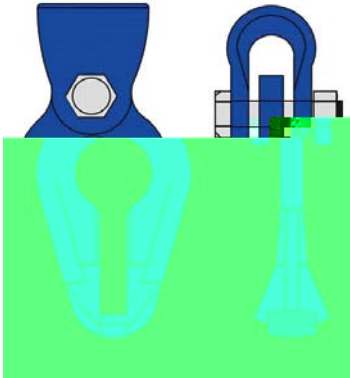

Individually proof test at 2.5 times Working Load  
 Fatigue tested at 1.5 times Working Load Limit

G

**KLR-717** G100 CHAIN-ROPE CONNECTOR G100

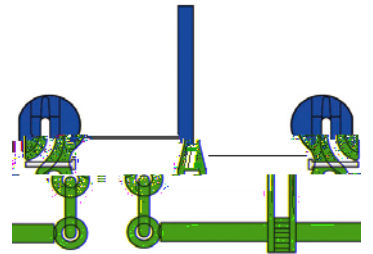
**KLR-750** G100 RATCHET BINDER WITH SAFETY HOOKS G100

Never exceed Working Load Limit

# G100 RIGGING

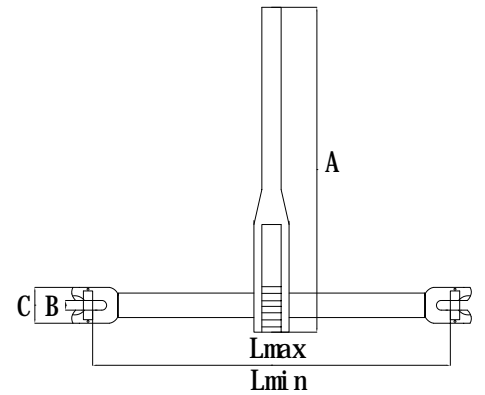
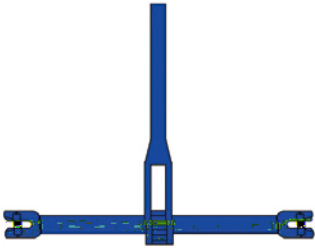

**KLR-751** G100 CLEVIS TYPE RACHET BINDER WITH G100

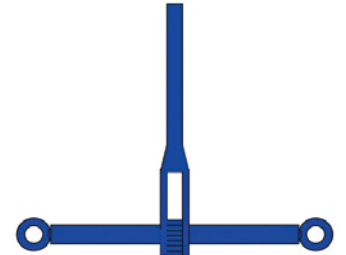
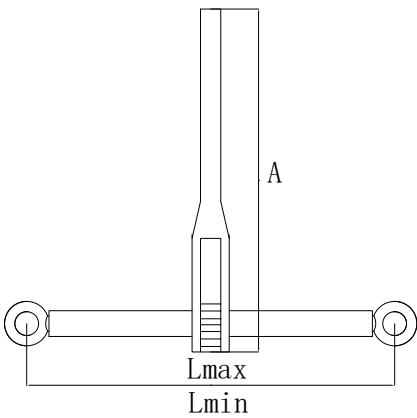
**KLR-752** G100 RACHET BINDER WITHOUT LINKS AND HOOKS G100

Never exceed Working Load Limit

# G100 RIGGING



Individually proof test at 2.5 times Working Load  
 Fatigue tested at 1.5 times Working Load Limit

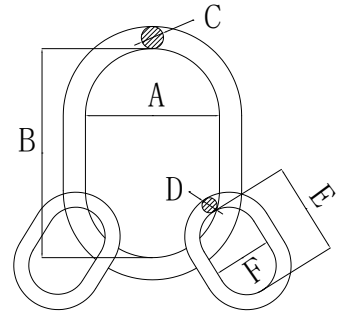

KLR-722 G100 MASTER LINK ASSEMBLY G100

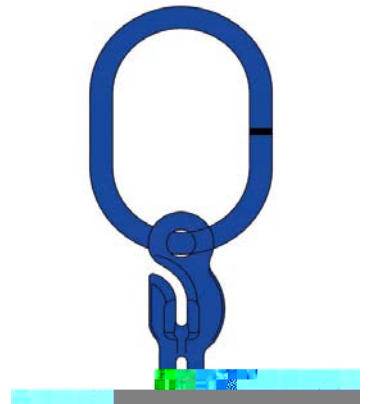
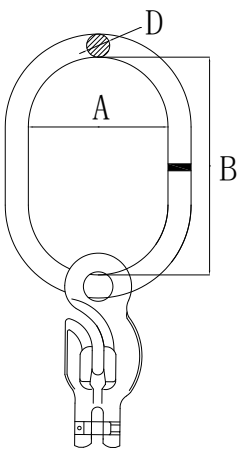

KLR-735 G100



Never exceed Working Load Limit

# G100 RIGGING

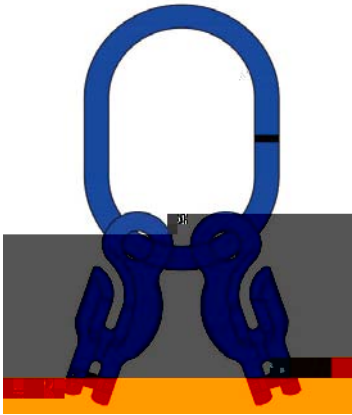

Individually proof test at 2.5 times Working Load Limit.  
 Fatigue tested at 1.5 times Working Load Limit for 20000

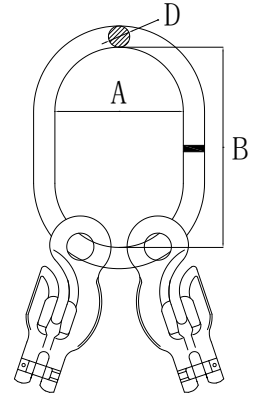

KLR-736 G100

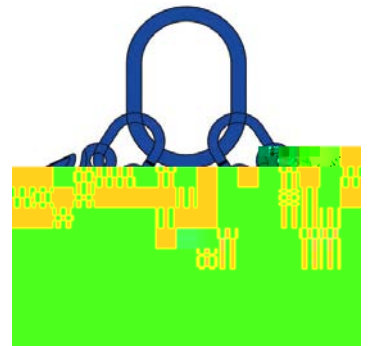
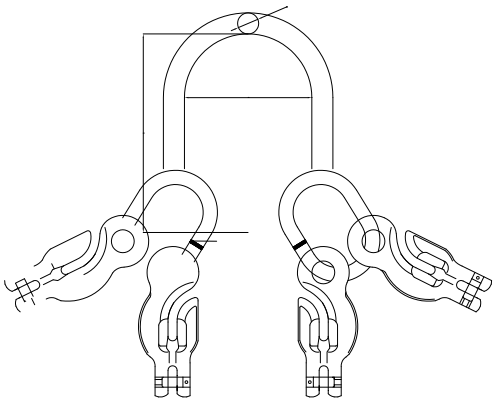

Never exceed Working Load Limit